

TC-10-0000000

TRUCK TIRE CHANGER FINISHED PRODUCT DRAWING

REVISION A-01

I
2 : 15

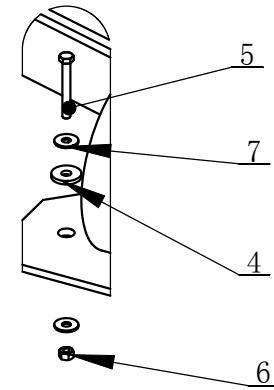

II
2 : 25

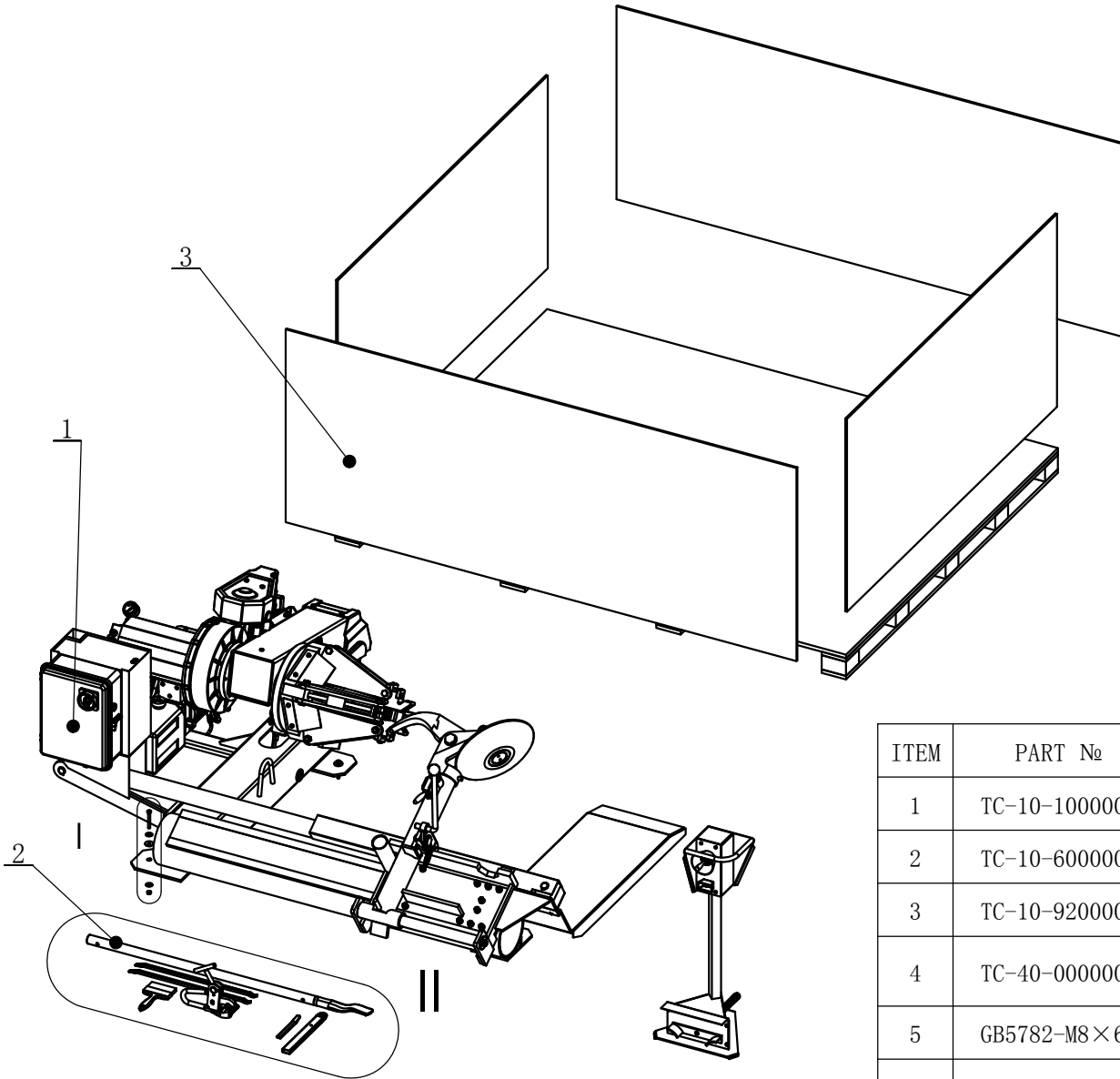
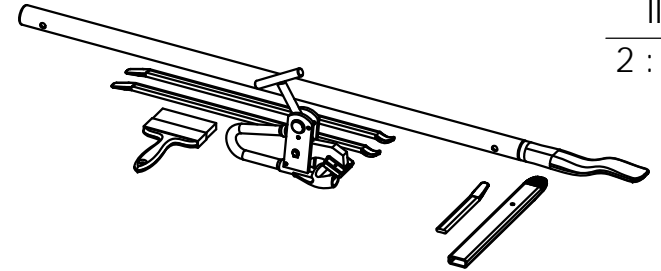

ITEM	PART №	DESCRIPTION	QTY
1	TC-10-1000000	TIRE CHANGER ASSEMBLE GENERAL	1
2	TC-10-6000000	ACCESSORY (STANDARD)	1
3	TC-10-9200000	EXPORT STEEL BEND PLYWOOD PACKAGE (COMMON)	1
4	TC-40-0000001	RUBBER GASKET	3
5	GB5782-M8×65	HEXANGULAR BOLT	3
6	GB41-M8	HEXANGULAR NUT	3
7	GB96-8	LARGE WASHER C GRADE	6

designed by:

checked by:

approved by:

TC-10-1000000

TC-10-1000000 TIRE CHANGER ASSEMBLE GENERAL

REVISION A-01

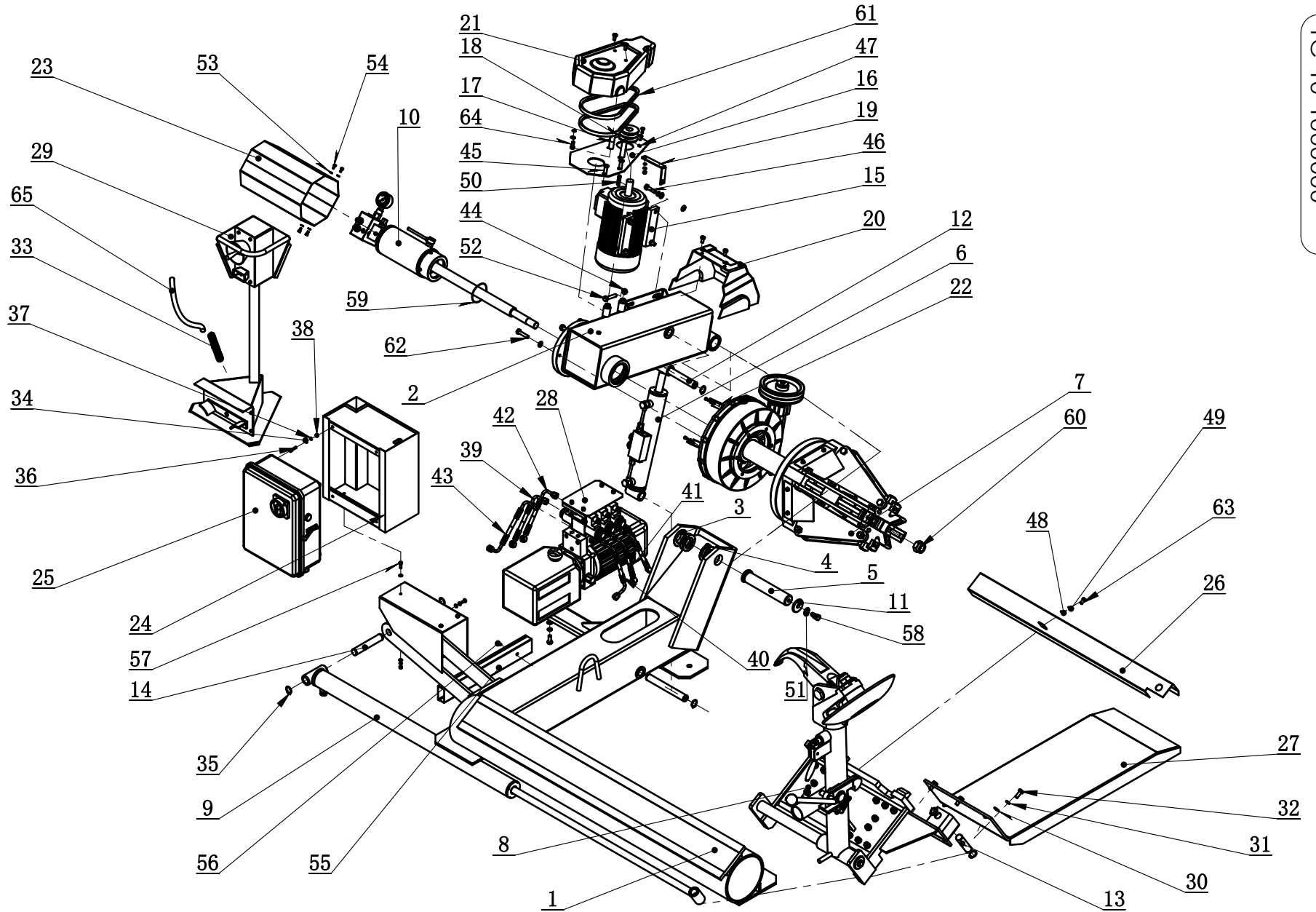

TC-10-1000000

designed by: checked by: approved by:

REVISION A-01

TC-10-1000000 TIRE CHANGER ASSEMBLE GENERAL				65	TC-10-1000028	power line	1
ITEM	PART. No	DESCRIPTION.	QTY	ITEM	PART. No	DESCRIPTION.	QTY
33	TC-10-1000025	CABLE PROTECTIVE SPRING	1	64	GB5783-M8×20	HEXANGULAR BOLT	2
32	GB5783-M10×25	HEXANGULAR BOLT	5	63	GB5783-M8×16	HEXANGULAR BOLT	5
31	GB93-10	STANDARD SPRING WASHER	9	62	GB5783-M10×45	HEXANGULAR BOLT	6
30	GB95-10	FLAT WASHER	19	61	TC-10-1000017	COMMON V-BELT-A710	2
29	TC-10-1B00000	CONSOLE	1	60	GB889. 2-M24×2	1-TYPEPREVAILING TORQUE TYPE HEXAGON LOCK NUT, SMALL TOOTH	1
28	TC-10-1030000	HYDRAULIC STATION ASSEMBLY	1	59	TC-10-1000024	MAIN SHAFT O-RING	1
27	TC-10-1500000	TRAIL ASSEMBLY	1	58	GB5783-M12×25	HEXANGULAR BOLT	1
26	TC-10-1020000	TRAIL OIL TANK COVER ASSEMBLY	1	57	GB5783-M6×20	HEXANGULAR BOLT	3
25	TC-10-1A00000	ELECTRICAL CONTROL CABINET 380V 50Hz	1	56	GB818-M6×16-H	CROSS PANHEAD SCREW	4
24	TC-10-1900000	TOOL BOX	1	55	TC-10-1000026	WIRING CHANNEL 60*30	1
23	TC-10-1010000	MAINSHAFT OIL TANK COVER ASSEMBLY WELDING	1	54	GB70- M5×10	INNER HEXA CYLINDRICAL SCREW	8
22	TC-10-1000007	SUPPORT ANGLE IRON	2	53	GB95-5	FLAT WASHER	8
21	TC-10-1000012	PULLEY COVER	1	52	GB5782-M10×50	HEXANGULAR BOLT	2
20	TC-10-1000001	VERTICAL MOVABLE ARM BACK COVER	1	51	GB95-12	FLAT WASHER	1
19	TC-10-1000008	RACK	1	50	GB1096-8×7×40	COMMON FLAT KEY	1
18	TC-10-1000014	SMALL PULLEY	1	49	GB93-8	STANDARD SPRING WASHER	3
17	TC-10-1000015	CONNECTING PIN	2	48	GB95-8	FLAT WASHER	5
16	TC-10-1000010	MOTOR PULLEY COVER PLATE	1	47	GB77-M6×8	INNER HEXA FLAT TERMINUS SET SCREW	1
15	TC-10-1000027	3-PHASE ASYNCHRONOUS MOTOR 380V	1	46	GB5783-M10×40	HEXANGULAR BOLT	4
14	TC-10-1000006	LONG PIN SHAFT	1	45	GB819. 1-M10×30-H	CROSS COUNTERSUNK SCREW STEEL 4. 8 GRADE	2
13	TC-10-1000005	SHORT PIN SHAFT	1	44	GB41-M10	HEXANGULAR NUT	8
12	TC-10-1000002	VERTICAL MOVABLE ARM LINK SHAFF	2	43	TC-10-1000023	MAIN SHAFT OIL TANK PIPE (1200)	1
11	TC-10-1300002	CIRCULAR GUIDERAIL WAHER	1	42	TC-10-1000019	TRAIL OIL TANK OIL PIPE(1800)	1
10	TC-10-1600000	MIANSHAFT OIL TANK AND OIL GUIDE ASSEMBLY	1	41	TC-10-1000021	VERTICAL OIL TANK PIPE(850)	1
9	TC-10-1800000	TRAIL OIL TANK ASSEMBLY	1	40	TC-10-1000022	MAIN SHAFT OIL TANK PIPE I (1200)	1
8	TC-10-1300000	RACK AND TIRE PRESS TOOL ASSEMBLY	1	39	TC-10-1000020	OIL PIPE (1020)	2
7	TC-10-1400000	RIM CLAMPING DEVICE	1	38	GB41-M6	HEXANGULAR NUT	8
6	TC-10-1700000	VERTICAL MOVEMENT OIL TANK ASSEMBLY	1	37	GB93-6	STANDARD SPRING WASHER	8
5	TC-10-1000016	VERTICAL MOVABLE ARM SUPPORT SHAFT	1	36	GB70. 1-M6×25	INNER HEXA CYLINDRICAL SCREW	4
4	TC-10-1000004	WEAR PAD 2	4	35	GB894. 1- 24	SHAFT ELASTIC RETAINING RING A 24	8
3	TC-10-1000003	WEAR PAD 1	2	34	GB95-6	FLAT WASHER	18
2	TC-10-1200000	VERTICAL ARM ASSEMBLY	1				
1	TC-10-1100000	BODY ASSEMBLE WELDING	1				

designed by: checked by: approved by:

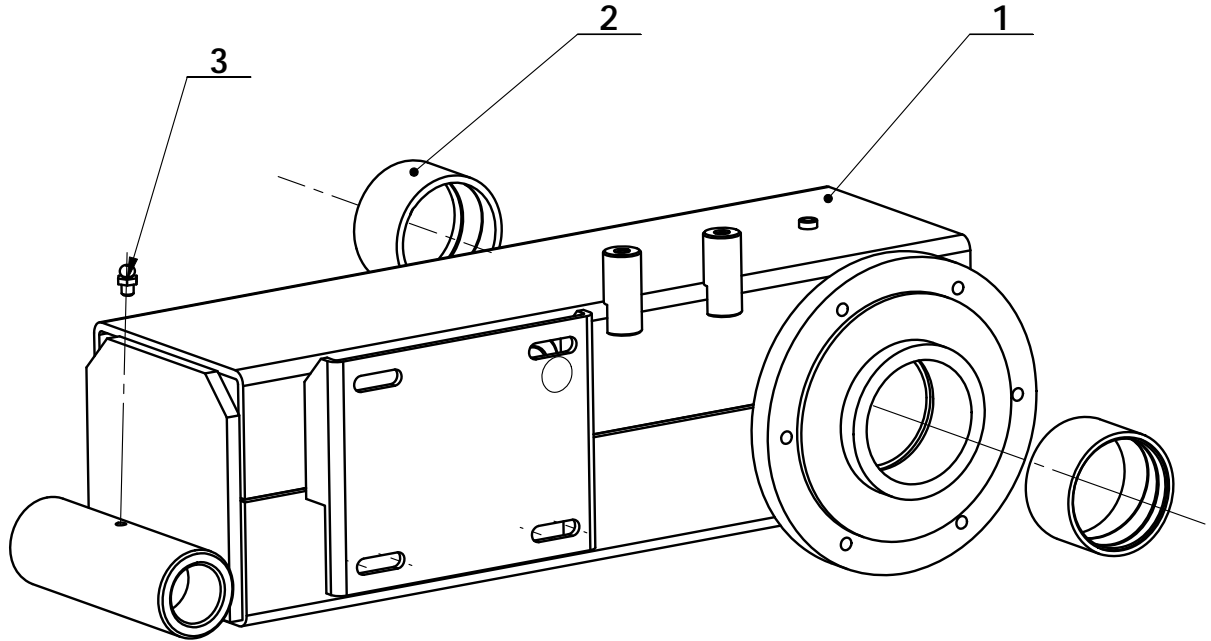

ITEM	PART. No	DESCRIPTION.	QTY
1	TC-10-1210000	VERTICAL ARM ASSEMBLY WELDING	1
2	TC-10-1200001	BEARING BUSHING	2
3	TC-40-1200023	OIL FILLING NOZZLE	1

designed by:

checked by:

approved by:

TC-10-1000000

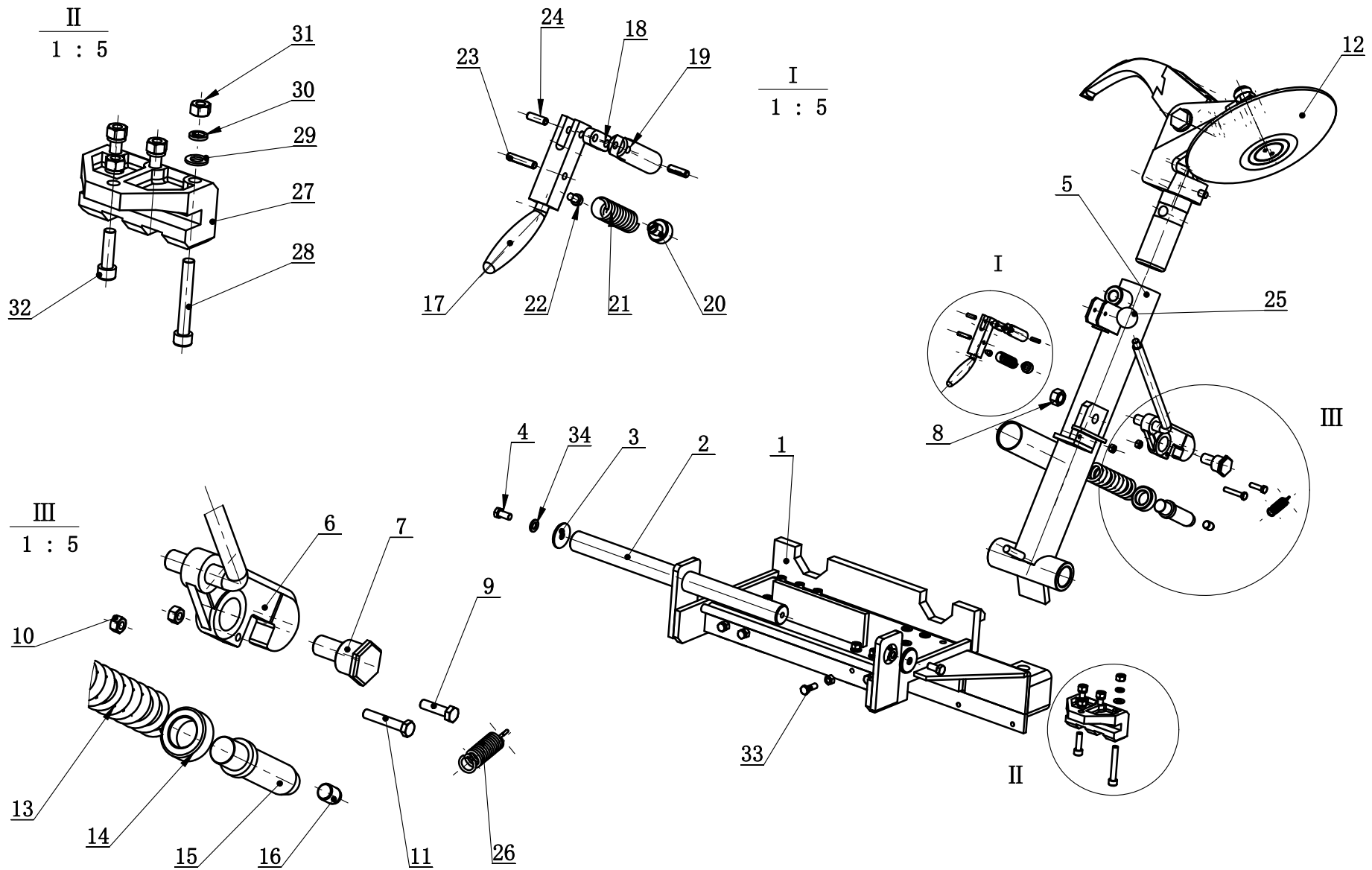

designed by: checked by: approved by:

ITEM	PART. No	DESCRIPTION.	QTY	ITEM	PART. No	DESCRIPTION.	QTY
1	TC-10-1310000	BRACKET ASSEMBLY WELDING	1	18	TC-10-1300005	CONNECT PLATE	1
2	TC-10-1300003	TRAILER CIRCULAR GUIDERAIL	1	19	TC-10-1300006	PIN-FIX	1
3	TC-10-1300002	CIRCULAR GUIDERAIL WAHER	2	20	TC-10-1300007	POSITION STUD	1
4	GB5783-M12×25	HEXANGULAR BOLT	2	21	TC-10-1300008	PRESS SPRING	1
5	TC-10-1320000	TOOL SUPPORT	1	22	GB65-M6×10	SLOTTED CYLINDRICAL SCREW	1
6	TC-10-1330000	HOOK	1	23	GB879. 2-6×30	ELASTIC CYLINDRICAL PIN, LIGHT	1
7	TC-10-1300010	ECCENTRIC SHAFT	1	24	GB879. 2-6×20	ELASTIC CYLINDRICAL PIN, LIGHT	2
8	GB6171-M18×1.5	1-TYPE HEXA NUT	1	25	TC-10-1300015	HANDLE (JB272. 1-M12*25)	1
9	GB5783-M8×30	HEXANGULAR BOLT	1	26	TC-10-1300009	EXTENSION SPRING	1
10	GB41-M8	HEXANGULAR NUT	2	27	TC-10-1300001	GUIDERAIL SUPPORT	4
11	GB5783-M8×45	HEXANGULAR BOLT	1	28	GB70. 1-M10×70	INNER HEXA CYLINDRICAL SCREW	12
12	TC-10-1340000	DOUBLE TOOL ASSEMBLY	1	29	GB95-10	FLAT WASHER	16
13	TC-10-1300014	PRESS SPRING	1	30	GB93-10	STANDARD SPRING WASHER	16
14	TC-10-1300013	NUT BUSHING	1	31	GB41-M10	HEXANGULAR NUT	20
15	TC-10-1300012	SHAFT	1	32	GB70. 1-M10×35	INNER HEXA CYLINDRICAL SCREW	4
16	TC-10-1300011	WASHER	1	33	GB5783-M10×30	HEXANGULAR BOLT	4
17	TC-10-1300004	FIX LOCK PRESSER	1	34	GB95-12	FLAT WASHER	2

designed by:

checked by:

approved by:

TC-10-1340000 DOUBLE TOOL ASSEMBLY

REVISION A-01

TC-10-1000000

ITEM	PART. No	DESCRIPTION.	QTY
1	TC-10-1340007	CONNECT SHAFT	1
2	TC-10-1340009	DOUBLE TOOL SUPPORT	1
3	TC-10-1341000	TURNTABLE	1
4	TC-10-1340010	BEARING	2
5	TC-10-1340006	SPINDLE	1
6	TC-10-1340008	EXTENSION SPRING CONNECT PLATE	1
7	GB 889.1 - M24	1-TYPE PREVAILING TORQUE TYPE HEXAGON LOCK NUT	1
8	TC-10-1340001	SHARP-NOSE TOOL,	1
9	TC-10-1340003	FIX SCREW	2
10	TC-10-1340004	NUT	2
11	TC-10-1340002	PIN	1
12	TC-10-1340005	EXTENSION SPRING	1
13	GB119. 1-12×120	CYLINDRICAL PIN	1
14	TC-40-1200023	OIL FILLING NOZZLE	1

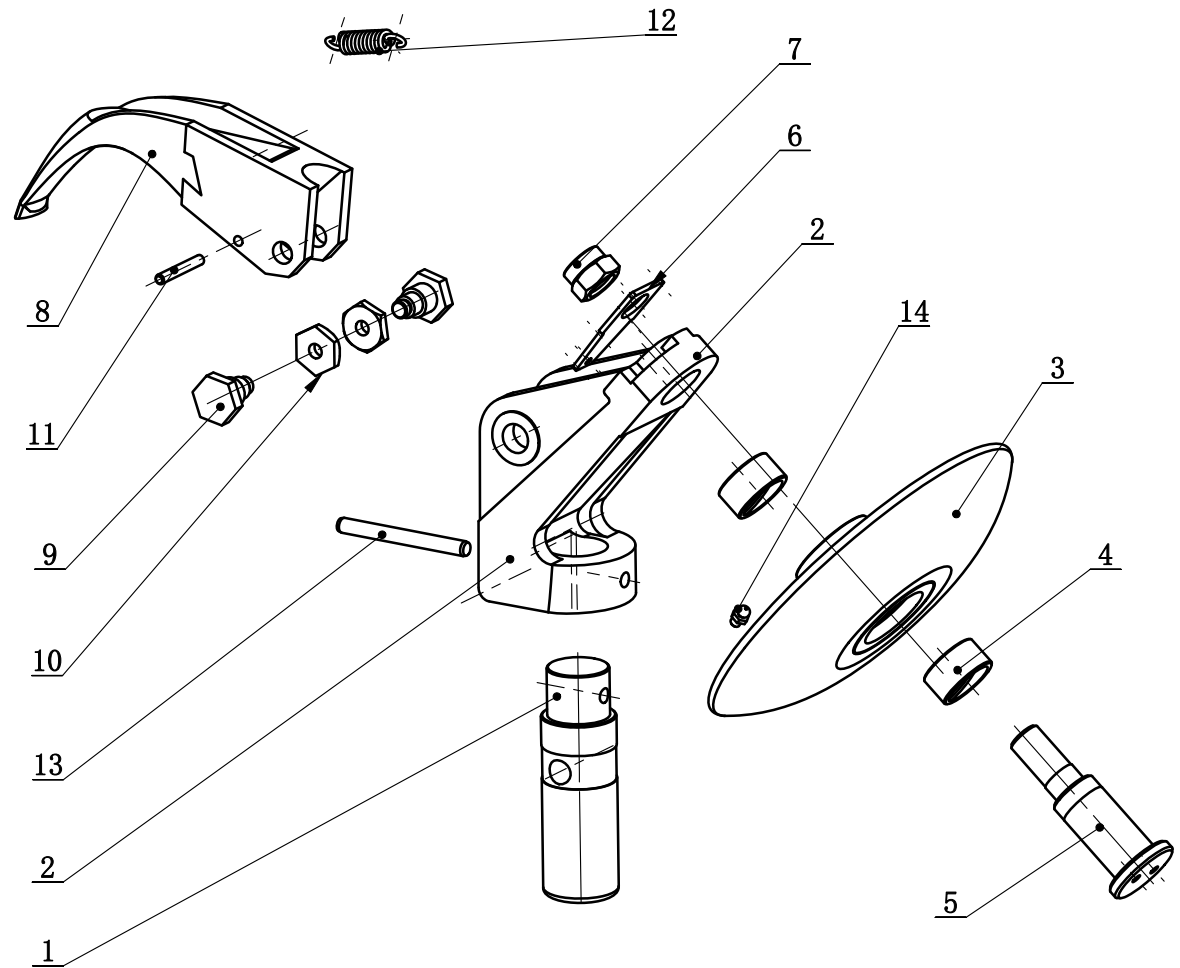

designed by:

checked by:

approved by:

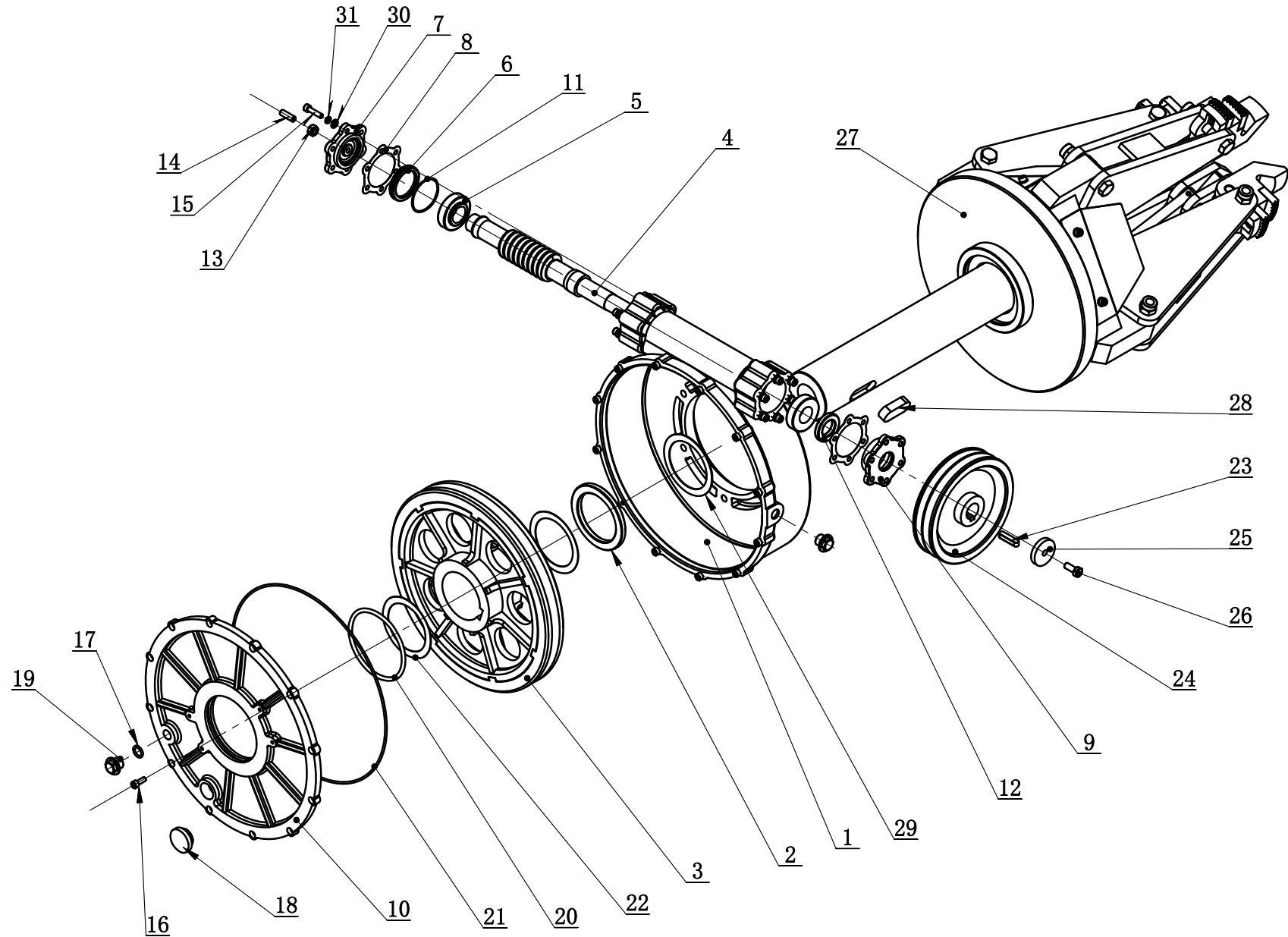

designed by:

checked by:

approved by:

ITEM	PART. No	DESCRIPTION.	QTY	ITEM	PART. No	DESCRIPTION.	QTY
1	TC-10-1400002	WORM CASE	1	19	TC-10-1400013	BOLT	2
2	TC-10-1400001	MAIN SHAFT ADJUSTING WASHER	1	20	GB3452. 1-100×5. 3-G	HYDRAULIC-PNEUMATIC RUBBER O-RING G TYPE	1
3	TC-10-1410000	WORM	1	21	GB3452. 1 300x2. 65	RING	1
4	TC-10-1400007	WORM SHAFT	1	22	TC-10-1400005	WASHER	2
5	GB297-94 30205	CONIC ROLLING BEARING	2	23	GB1096-8×7×36	COMMON FLAT KEY	1
6	TC-10-1400012	ADJUST WASHER	1	24	TC-10-1400010	LARGE PULLEY	1
7	TC-10-1400006	WORM CASE REAR COVER	1	25	TC-10-1400011	PULLEY RETAINING RING	1
8	TC-10-1400008	PAPER WASHER	2	26	GB5783-M8×20	HEXANGULAR BOLT	1
9	TC-10-1400009	WORM CASE FRONT COVER	1	27	TC-10-1420000	MAIN SHAFT AND CLAMP	1
10	TC-10-1400003	WORM CASE COVER	1	28	GB1096-20X50	FLAT WASHER 20*50	1
11	GB3452. 1- 48. 7x1. 8	RING	1	29	TC-10-1400004	WASHER	1
12	TC-10-1400015	SEALING WASHER W42X25X7	1	30	GB95-6	FLAT WASHER	12
13	GB41-M8	HEXANGULAR NUT	1	31	GB93-6	STANDARD SPRING WASHER	12
14	GB77-M8×25	INNER HEXA FLAT TERMINUS SET SCREW	1				
15	GB70. 1-M6×25	INNER HEXA CYLINDRICAL SCREW	12				
16	GB70. 1-M6×16	INNER HEXA CYLINDRICAL SCREW	12				
17	GB3452. 1 - 13. 2×2. 65-G	O-RING G 13. 2×2. 65-G	2				
18	TC-10-1400014	OIL DISPLAY M27X1. 5	1				

designed by: checked by: approved by:

TC-10-1420000 MAIN SHAFT AND CLAMP

REVISION A-01

TC-10-1000000

ITEM	PART. No	DESCRIPTION.	QTY
1	TC-10-1421000	CHUCK ASSEMBLY WELDING	1
2	TC-10-1421200	CLAMP SUPPORT	4
3	TC-10-1420005	PULLING PLATE	4
4	TC-10-1420004	PIN SHAFT	8
5	TC-10-1420006	CLAMP	4
6	TC-10-1420009	ROLLING STUD	4
7	TC-10-1420007	GRIPPING CLAW B	4
8	TC-10-1420008	GRIPPING CLAW B	4
9	TC-10-1420011	MAIN SHAFT BUSHING	1
10	TC-10-1420014	THREAD PIN	12
11	GB889. 1-M14	1-TYPE PREVAILING TORQUE TYPE HEXAGON LOCK NUT	12
12	GB79-M6×10	INNER HEXA CYLINDRICAL TERMINUS SET SCREW	8
13	GB70. 1-M8×16	INNER HEXA CYLINDRICAL SCREW	12
14	TC-10-1420013	PROTECTIVE PANEL	4
15	GB70. 1-M6×10	INNER HEXA CYLINDRICAL SCREW	8
16	TC-10-1420001	PROTECTIVE COVER	1
17	GB95-6	FLAT WASHER	8
18	TC-10-1420002	RBRACKET	1
19	TC-10-1420003	PAD	1
20	TC-10-1420012	PAD	1
21	TC-10-1420010	ADJUSTABLE WASHER	24

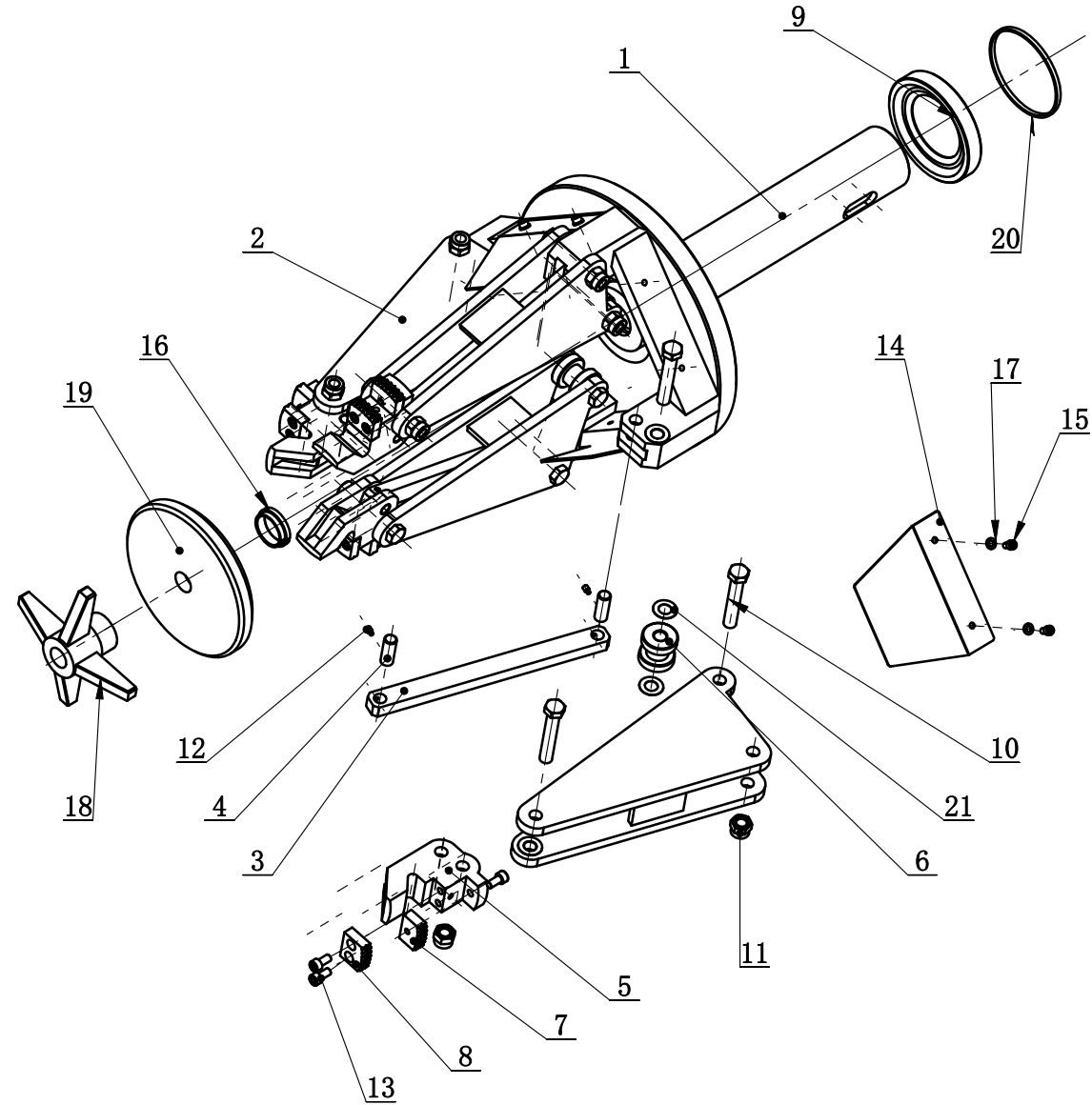

designed by:

checked by:

approved by:

TC-10-1500000 TRAIL ASSEMBLY

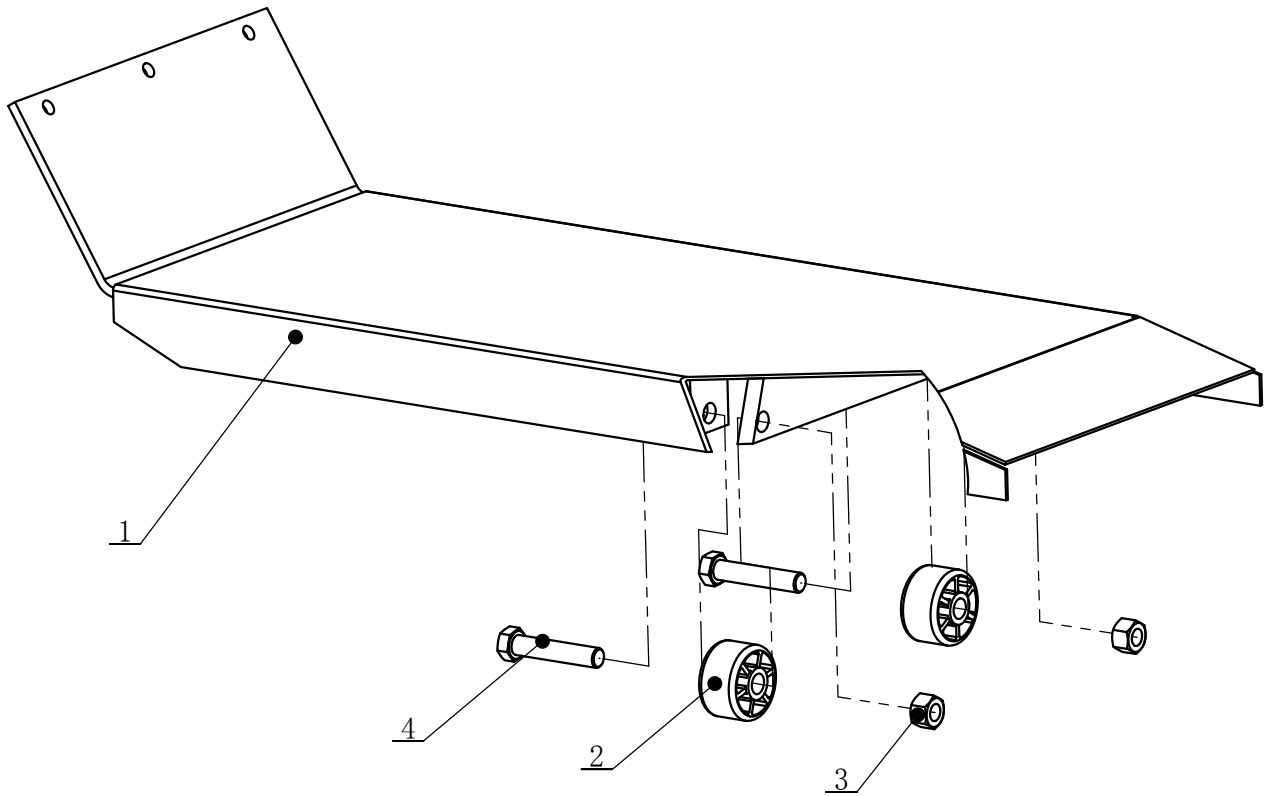

ITEM	PART. No	DESCRIPTION.	QTY
1	TC-10-1510000	TRAILER ASSEMBLY WELDING	1
2	TC-10-1500001	ROLLING WHEEL	2
3	GB41-M16	HEXANGULAR NUT	2
4	GB5782-M16×80	HEXANGULAR BOLT	2

designed by:

checked by:

approved by:

TC-10-1600000 MIANSHAFT OIL TANK AND OIL GUIDE ASSEMBLY

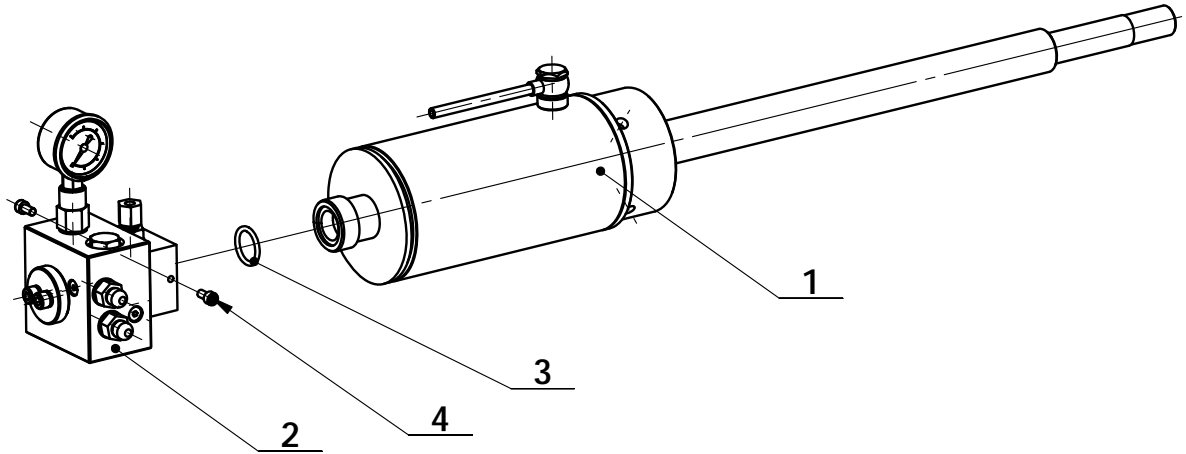

ITEM	PART. No	DESCRIPTION.	QTY
1	TC-10-1610000	MAIN SHAFT OIL TANK ASSEMBLY	1
2	TC-10-1620000	OIL GUIDE ASSEMBLY PARTS	1
3	GB3452.1 25×3.55	O-RING G 25×3.55-G	1
4	GB70.1-M6×12	INNER HEXA CYLINDRICAL SCREW	2

designed by: checked by: approved by:

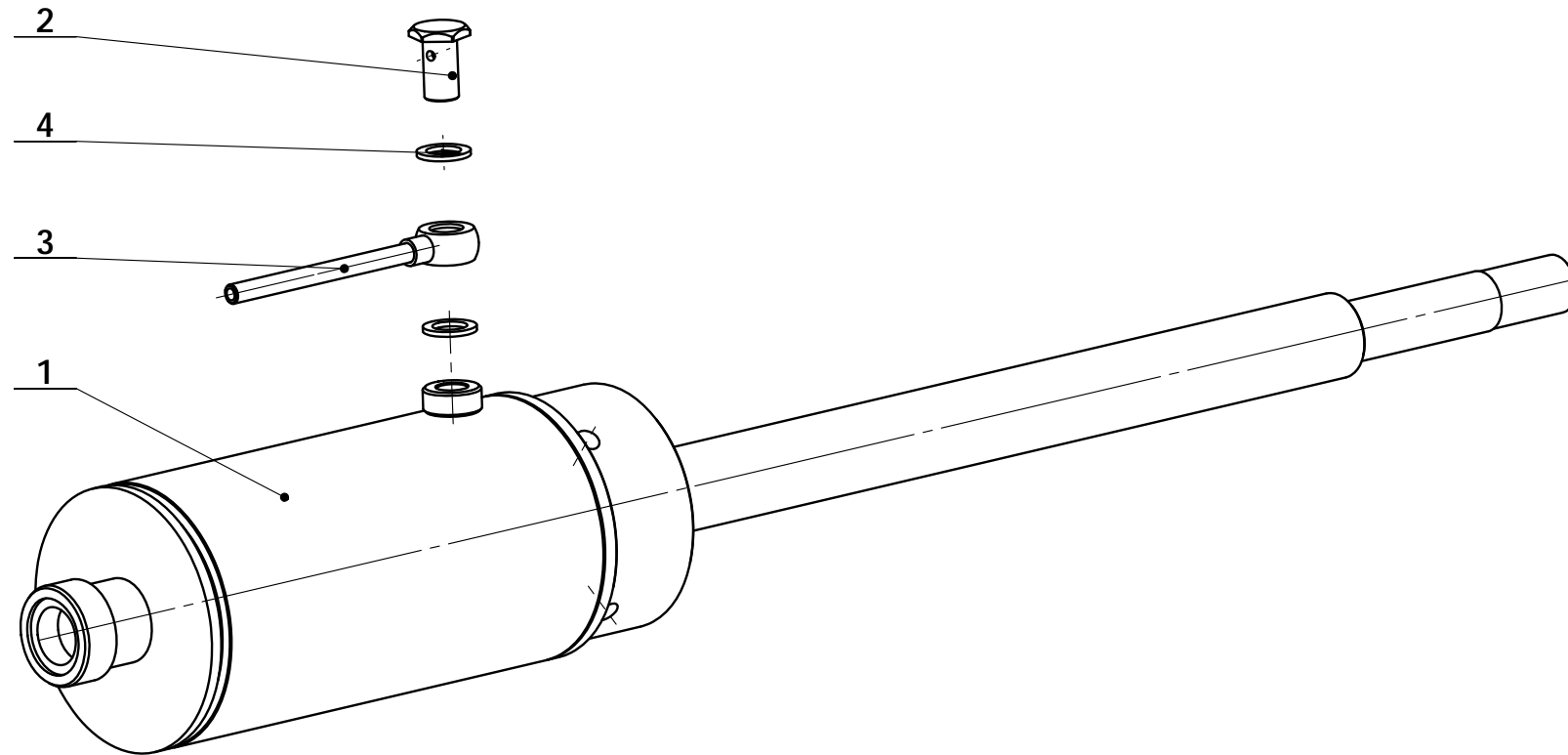

ITEM	PART. No	DESCRIPTION.	QTY
1	TC-10-1611000	MAIN SHAFT OIL TANK ASSEMBLY GENERAL	1
2	TC-10-1610001	OIL PIPE JOINT	1
3	TC-10-1612000	OIL PIPE JOINT ASSEMBLY WELDING	1
4	TC-10-1610005	COPPER PAD 22X14X2	2

designed by:

checked by:

approved by:

TC-10-1611000 MAIN SHAFT OIL TANK ASSEMBLY GENERAL

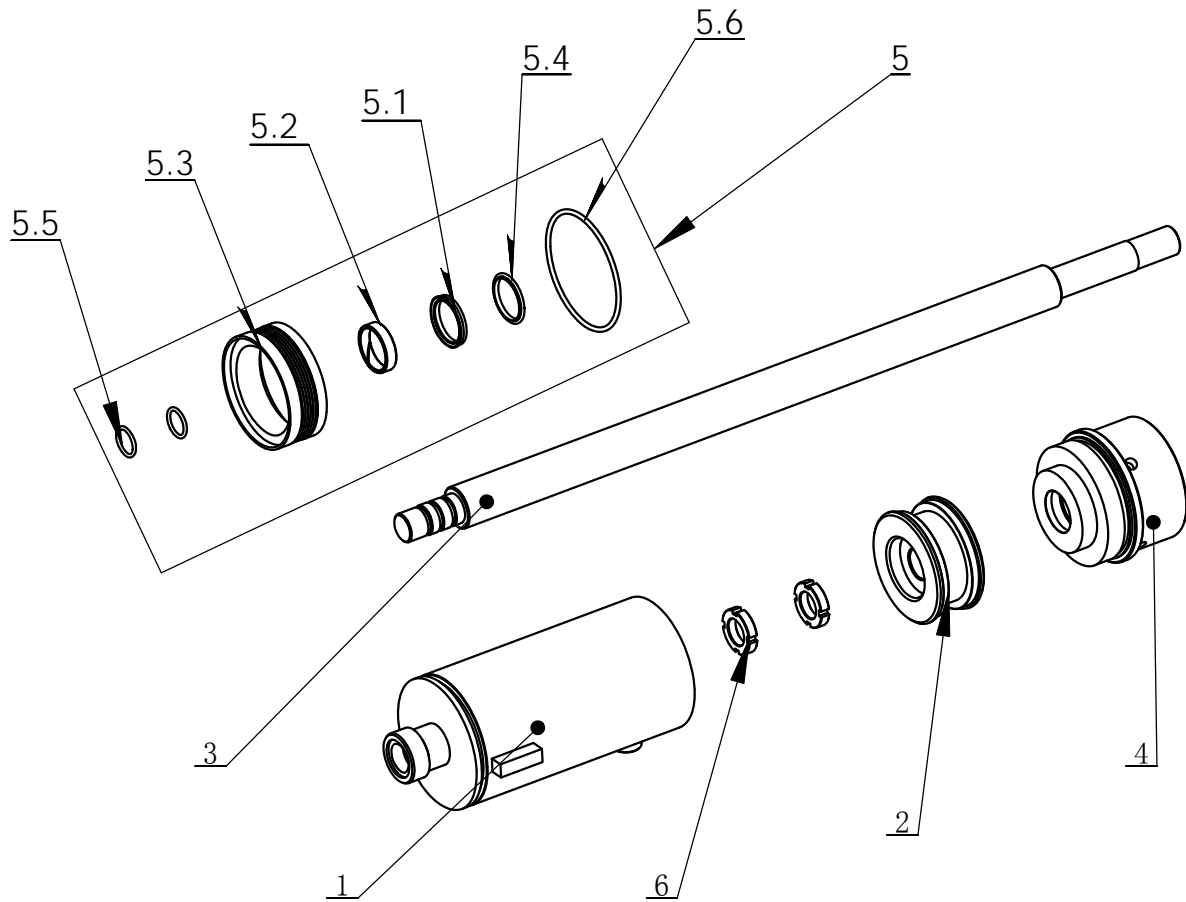

ITEM	PART. No	DESCRIPTION.	QTY
1	TC-10-1611100	MAIN SHAFT OIL TANK BODY	1
2	TC-10-1611001	PISTON	1
3	TC-10-1611002	PISTON ROD	1
4	TC-10-1611003	OIL TANK FRONT COVER	1
5	TC-10-1611200	MAIN SHAFT CYLINDER SEALING PARTS ASSEMBLY	1
5.1	TC-10-1611004	SUPPORT RING	1
5.2	TC-10-1611005	WEAR-RESISTENCE RING GT-9.7B	1
5.3	TC-10-1611006	SEALING RING	1
5.4	TC-10-1611007	C141 RING 35x42.2X4	1
5.5	GB3452.1- 20.6×2.65	O-RING G 20.6×2.65-G	2
5.6	GB3452.1-95*3.55	O-RING G 95*3.55-G	1
6	GB/T810- M24X1.5	NUT	2

designed by:

checked by:

approved by:

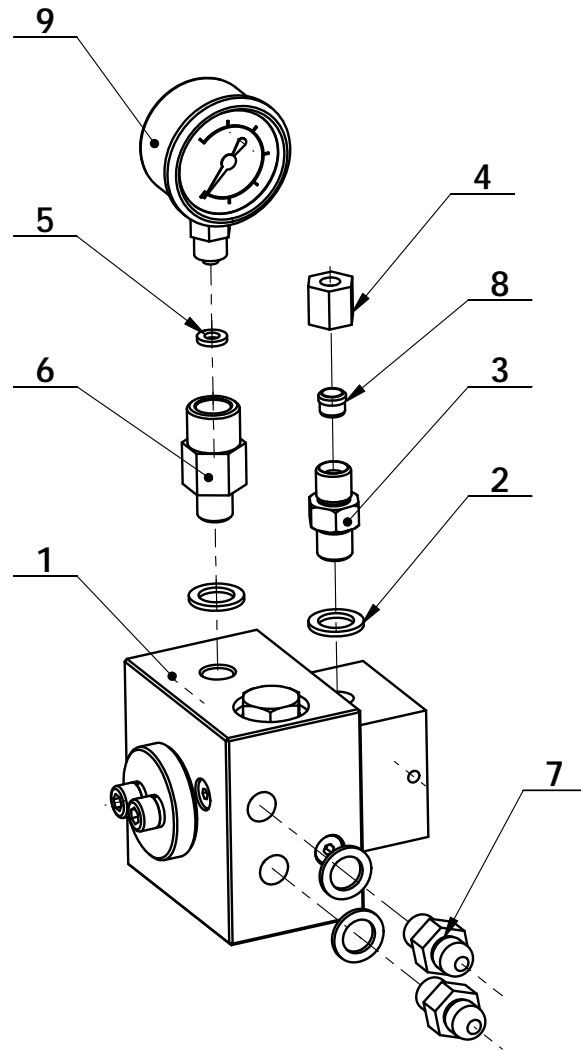

ITEM	PART. No	DESCRIPTION.	QTY
1	TC-10-1621000	OIL GUIDE ASSEMBLY	1
2	TC-10-1610005	COPPER PAD 22X14X2	4
3	TC-10-1620001	OIL PIPE DOUBLE SCREW ROD	1
4	TC-10-1620002	NUT-LOCK	1
5	TC-10-1620003	WASHER	1
6	TC-10-1620004	PRESSURE GAUGE JOINT	1
7	TC-10-1620005	OIL ROUTE DOUBLE SCREW ROD	2
8	TC-10-1620006	CLAMP BUSHING	1
9	TC-10-1620007	PRESSURE GAUGE	1

designed by:

checked by:

approved by:

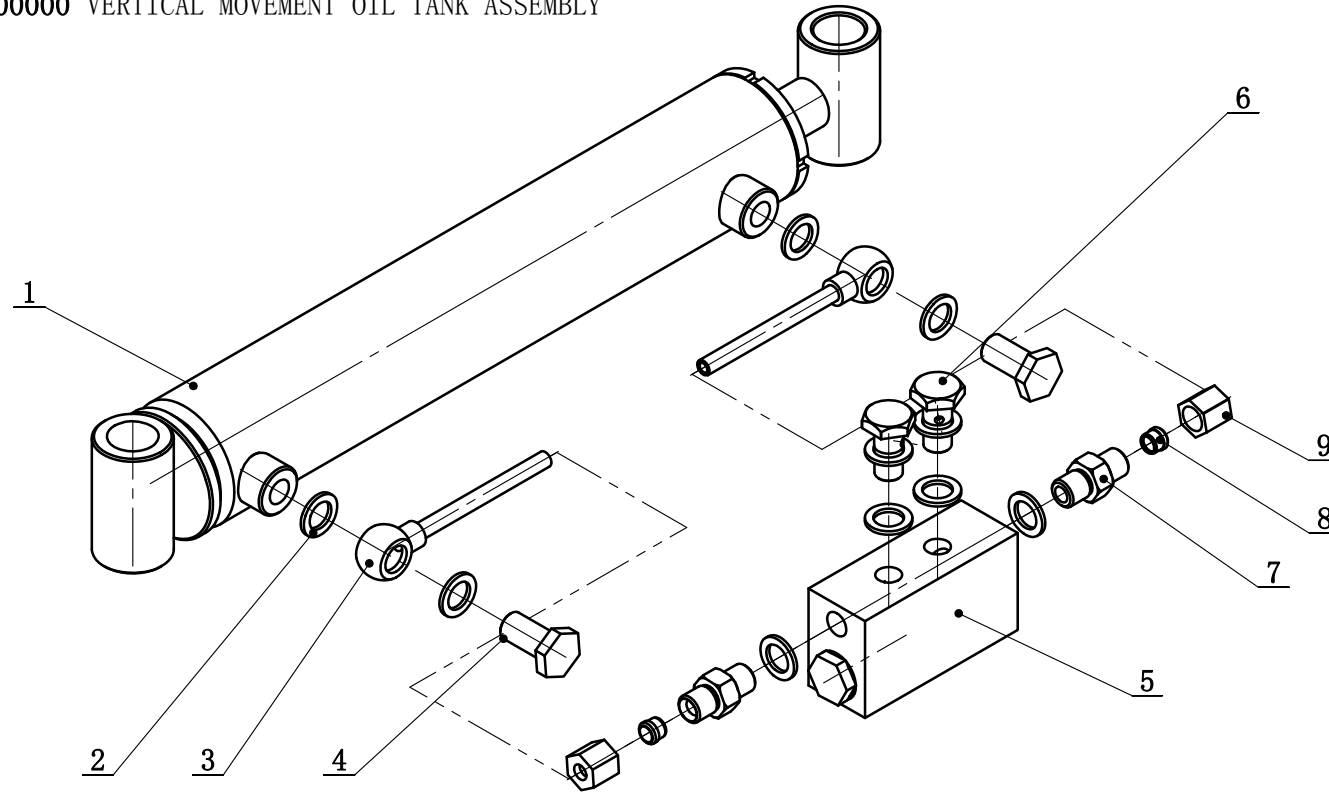

ITEM	PART. No	DESCRIPTION.	QTY
1	TC-10-1720000	VERTICAL OIL TANK	1
2	TC-10-1610005	COPPER PAD 22X14X2	10
3	TC-10-1710000	OIL PIPE JOINT NOZZAL ASSEMBLY WELDING	2
4	TC-10-1700001	NOZZAL	2
5	TC-10-1700003	HYDRAULIC LOCK	1
6	TC-10-1700002	OIL TUBE CONNECTOR	2
7	TC-10-1620001	OIL PIPE DOUBLE SCREW ROD	2
8	TC-10-1620006	CLAMP BUSHING	2
9	TC-10-1620002	NUT-LOCK	2

designed by:

checked by:

approved by:

TC-10-1720000 VERTICAL OIL TANK

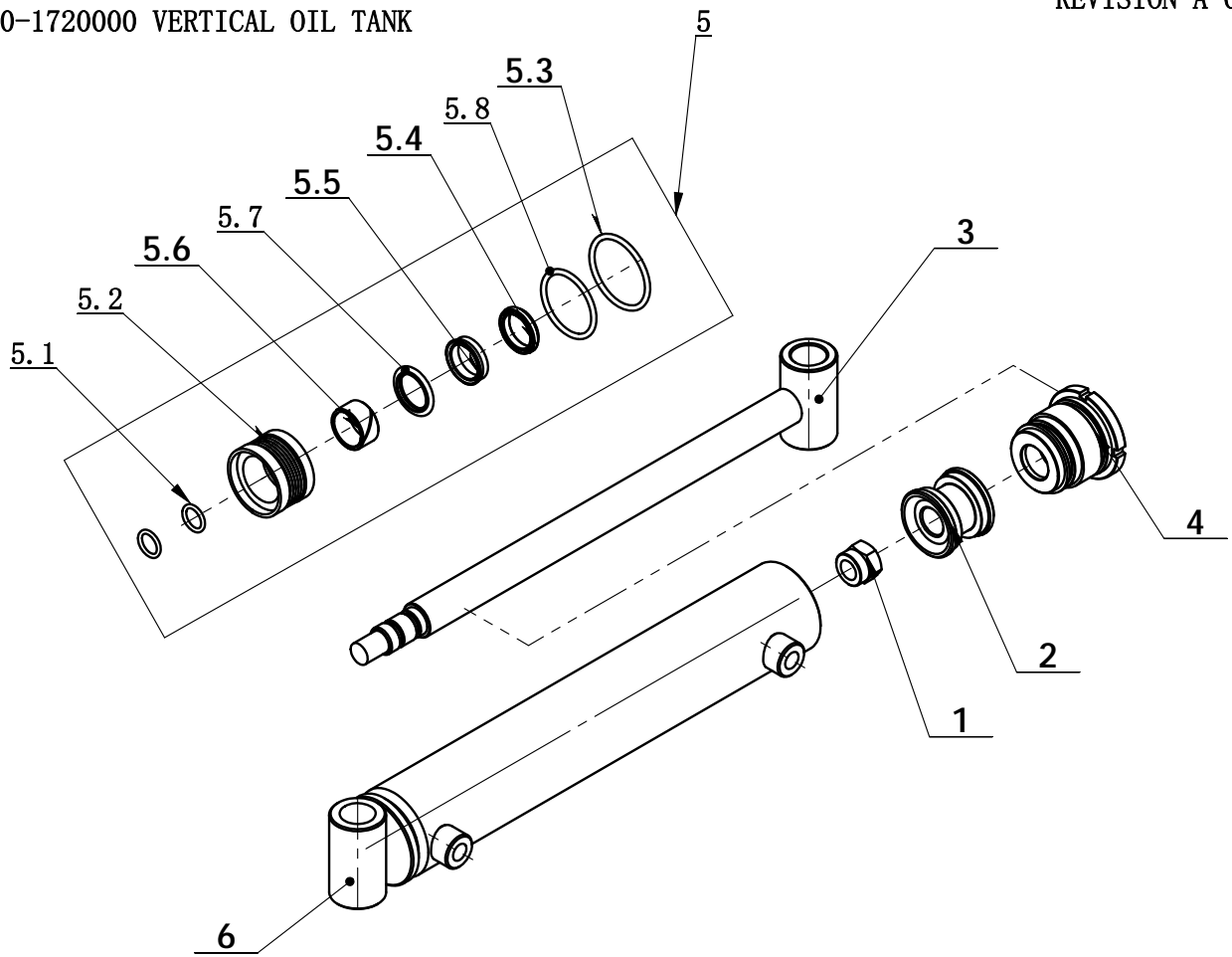

ITEM	PART. No	DESCRIPTION.	QTY
1	GB889. 2-M16×1. 5	1-TYPEPREVAILING TORQUE TYPE HEXAGON LOCK NUT, SMALL TOOTH M16×1. 5	1
2	TC-10-1720001	PISTON	1
3	TC-10-1722000	PISTON ROD ASEMBLY WELDING PART	1
4	TC-10-1720002	OIL TANK HEAD	1
5	TC-10-1723000	LIFTING CYCLINDER SEALING PARTS ASSEMBLY	1
5. 1	GB3452. 1-15*2. 65	O-RING G 15×2. 65-G	2
5. 2	TC-10-1720003	ASSEMBLY SEALING	1
5. 3	GB3452. 1-48. 7×3. 55	O-RING G 48. 7×3. 55-G	1
5. 4	TC-10-1720004	DUST-PROOF RING LBH-25	1
5. 5	TC-10-1720005	U SEALING RING 25x33x8. 2	1
5. 6	TC-10-1720006	SUPPORT RING GT-15B	1
5. 7	TC-10-1720007	SEALING RING φ 25 (GSJ0205)	1
5. 8	GB3452. 1-43. 7×3. 55	O-RING G 43. 7×3. 55-G	1
6	TC-10-1721000	OIL TANK BODY	1

设计:

审核:

批准:

TC-10-1800000 TRAIL OIL TANK ASSEMBLY

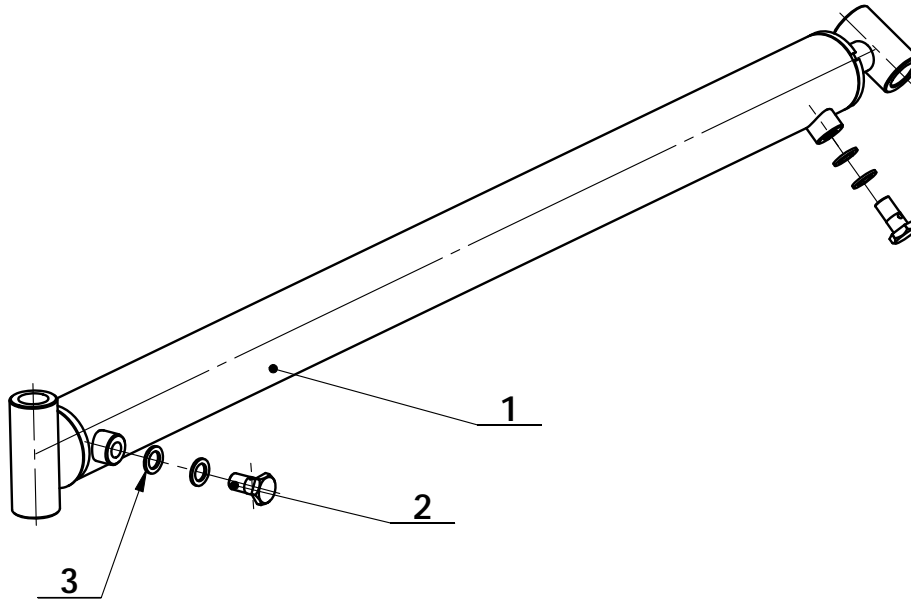

ITEM	PART. No	DESCRIPTION.	QTY
1	TC-10-1810000	BRACKET OIL TANK	1
2	TC-10-1700002	OIL TUBE CONNECTOR	2
3	TC-10-1610005	COPPER PAD 22X14X2	4

designed by:

checked by:

approved by:

TC-10-1810000 BRACKET OIL TANK

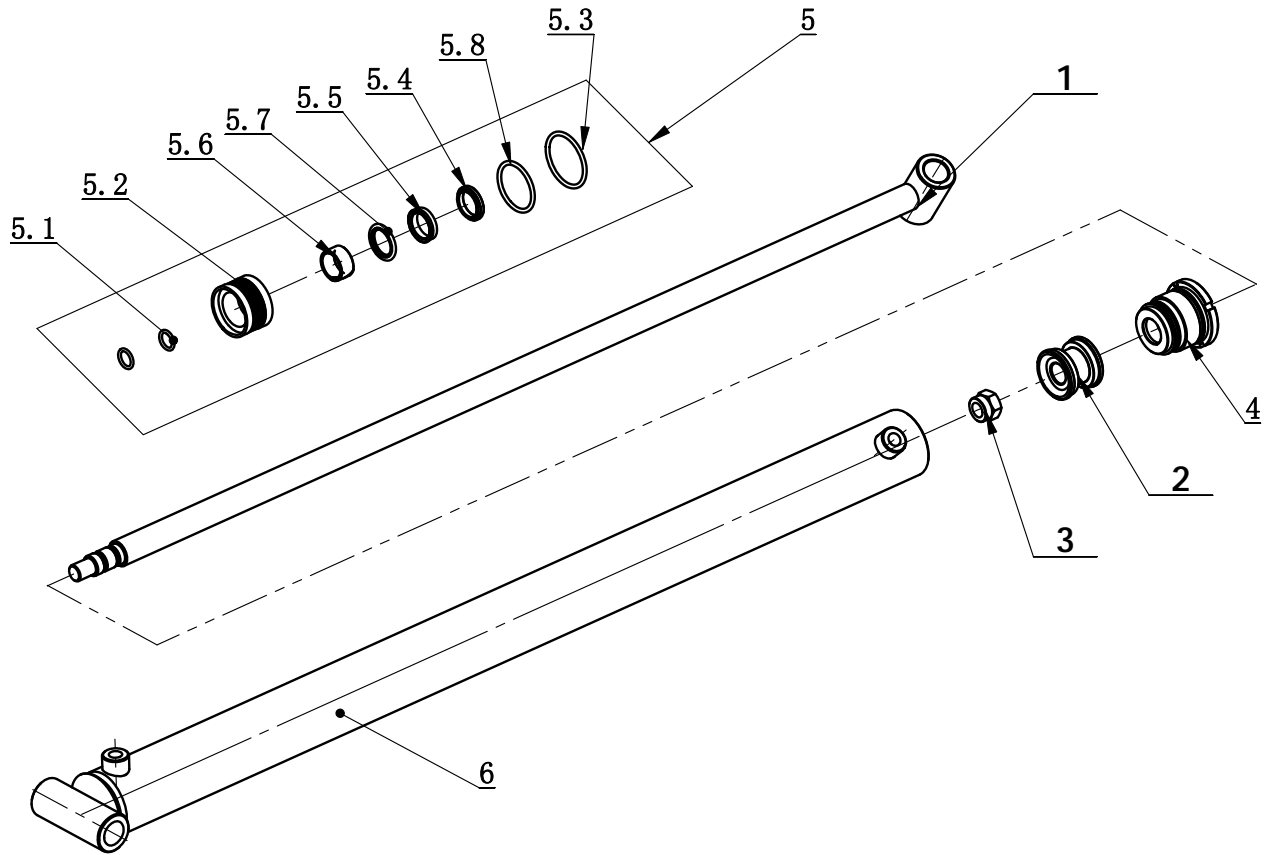

ITEM	PART. No	DESCRIPTION.	QTY
1	TC-10-1812000	PISTON ROD ASSEMBLY WELDING	1
2	TC-10-1720001	PISTON	1
3	GB889. 2-M16×1. 5	1-TYPEPREVAILING TORQUE TYPE HEXAGON LOCK NUT, SMALL TOOTH	1
4	TC-10-1720002	OIL TANK HEAD	1
5	TC-10-1723000	LIFTING CYCLINDER SEALING PARTS ASSEMBLY	1
5. 1	GB3452. 1-15*2. 65	O-RING G 15×2. 65-G	2
5. 2	TC-10-1720003	SEALING TW-5000034	1
5. 3	GB3452. 1-48. 7x3. 55	O-RING G 48. 7×3. 55-G	1
5. 4	TC-10-1720004	DUST-PROOF RING LBH-25	1
5. 5	TC-10-1720005	U SEALING RING 25x33x8. 2	1
5. 6	TC-10-1720006	SUPPORT RING GT-9. 7B	1
5. 7	TC-10-1720007	SEALING RING φ 25 (GSJ0205)	1
5. 8	GB3452. 1-43. 7×3. 55-G	O-RING G 43. 7×3. 55-G	1
6	TC-1811000	CYLINDER ASSEMBLY WELDING	1

designed by:

checked by:

approved by:

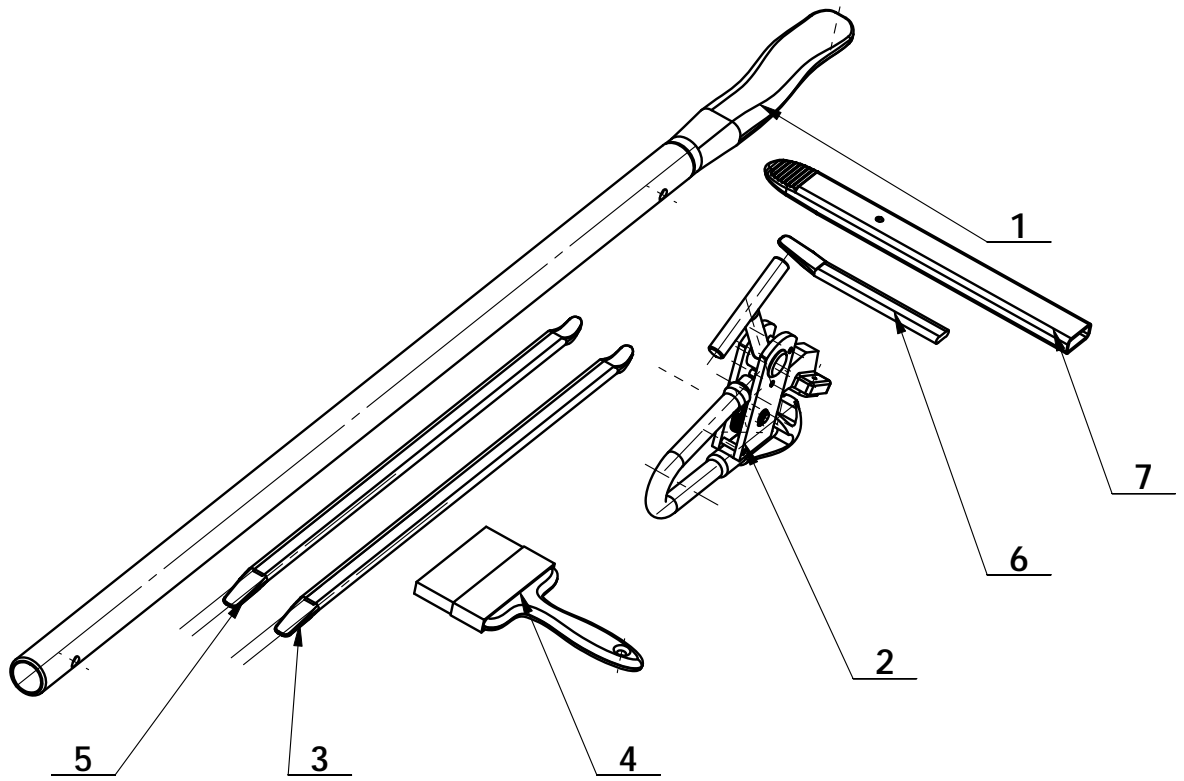

ITEM	PART. No	DESCRIPTION.	QT. Y
1	TC-10-6100000	CROWBAR	1
2	TC-10-6200000	CLAMP WITH COVER	1
3	TC-10-6000001	24" CROWBAR	1
4	TC-40-8000007	BRUSH-4"	1
5	C-01-1000008	20" CROWBAR	1
6	C-01-1000012	20INCH CROWBAR	1
7	TC-40-8000006	24INCH CROWBAR	1

designed by:

checked by:

approved by:

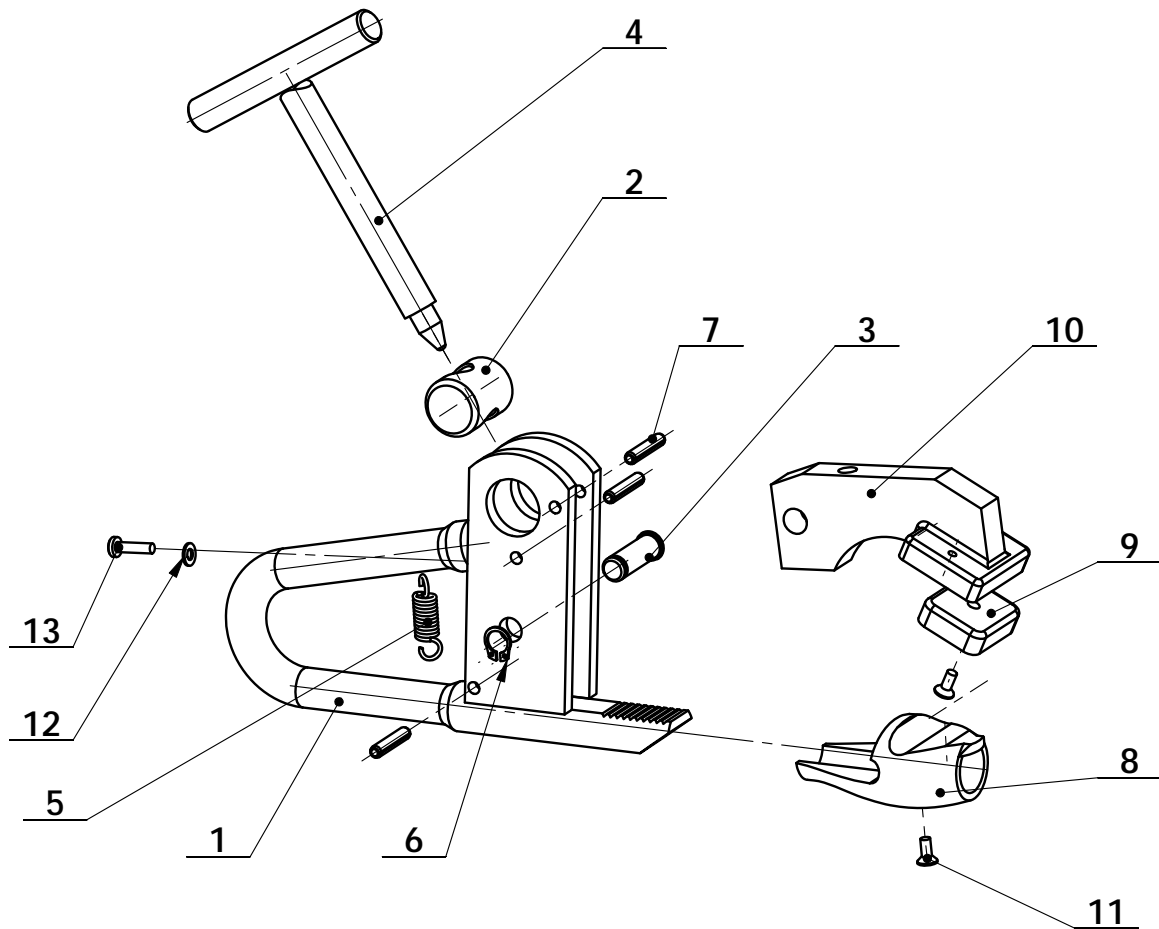

ITEM	PART. No	DESCRIPTION.	QTY
1	TC-10-6210000	CLAMP	1
2	TC-10-8200001	ROTATION SHAFT	1
3	TC-10-8200003	PIN	1
4	TC-10-8210000	HANDLE	1
5	TC-10-8200004	SPRING	1
6	GB894. 1-10	shaft elatic big retaining ring A-type	1
7	GB/T879. 1- 5×26	ELASTIC CYLINDRICAL PIN, HEAVY 5×26	3
8	TC-10-6200001	CLAMP COVER	1
9	TC-10-6200002	PROTECTIVE WASHER	1
10	TC-10-6200003	CLAMP PLANE	1
11	GB819. 1- M4×10	CROSS COUNTERSUNK SCREW M4×10-H	2
12	GB95-4	FLAT WASHER	1
13	GB818- M4×16	CROSS PANHEAD SCREW M4×16-H	1

designed by:

checked by:

approved by:

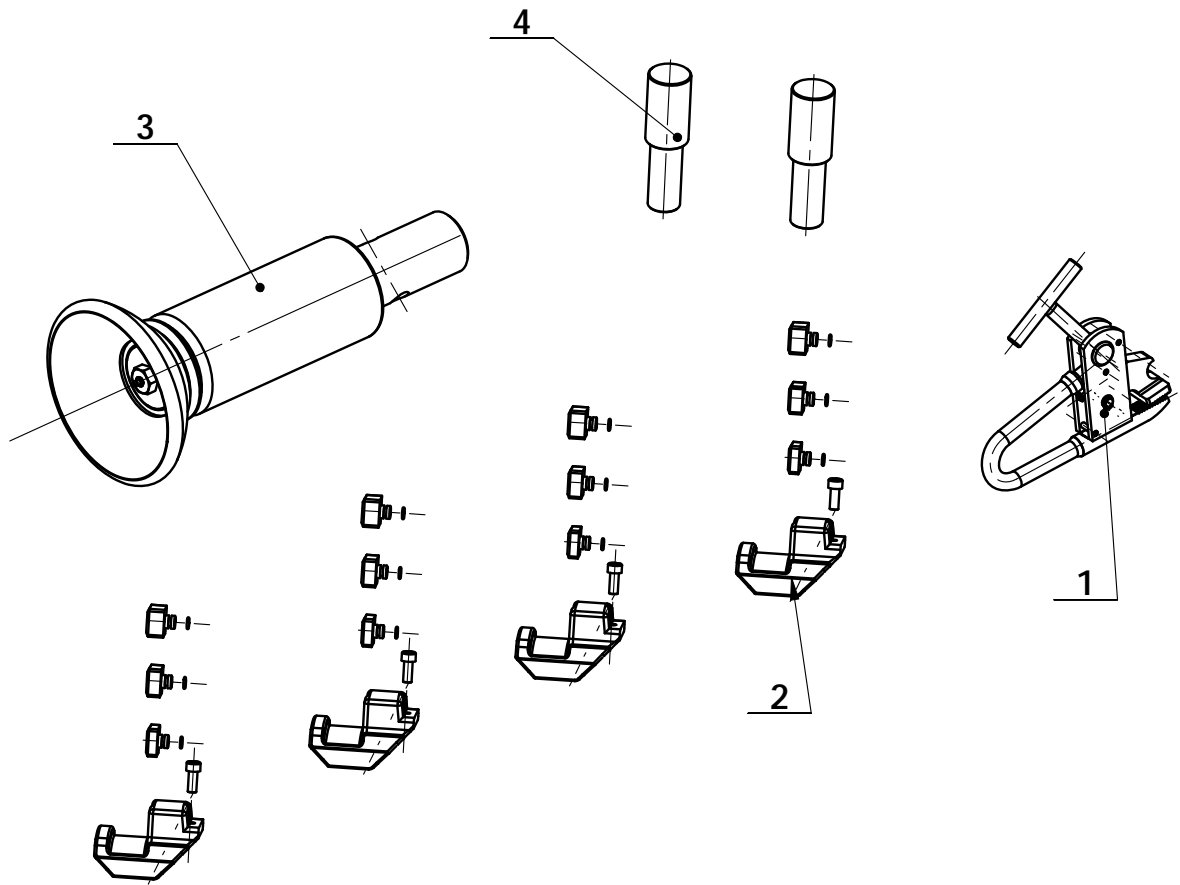

ITEM	PART. No	DESCRIPTION.	QTY
1	TC-10-8200000	CLAMP ASSEMBLY	1
2	TC-10-8300000	NYLON CLAMP COVER ASSEMBLY	4
3	TC-10-8400000	TIRE PRESSER ASSEMBLY	1
4	TC-20-8000001	SHAFT PIN	2

designed by:

checked by:

approved by:

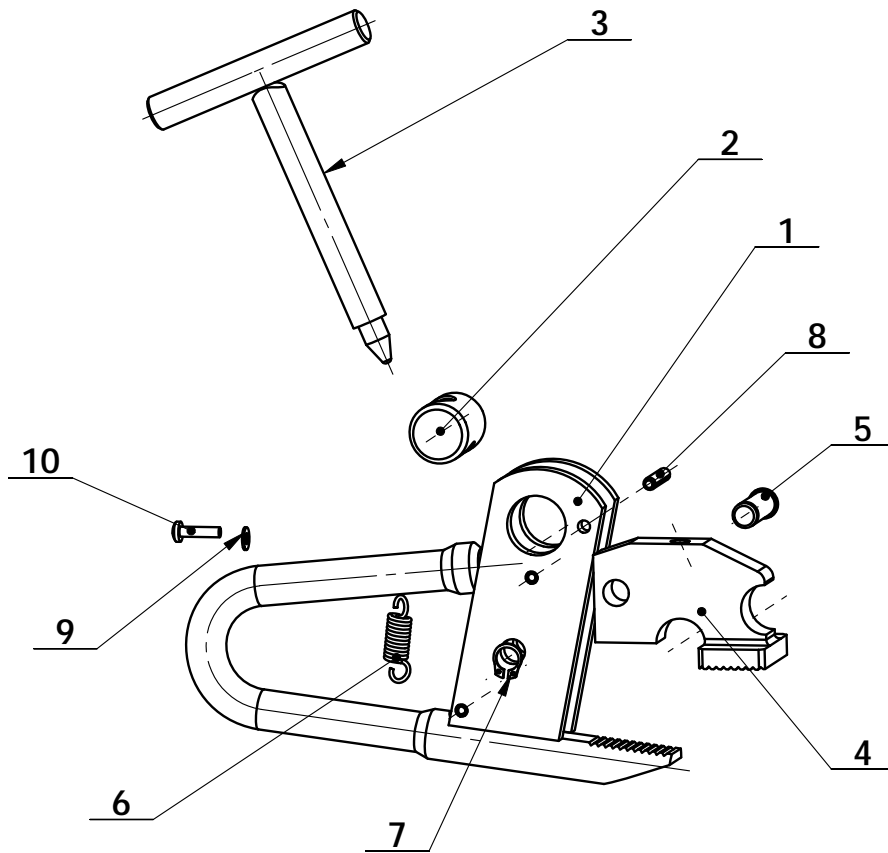

ITEM	PART. No	DESCRIPTION.	QTY
1	TC-10-8220000	CLAMP	1
2	TC-10-8200001	ROTATION SHAFT	1
3	TC-10-8210000	HANDLE	1
4	TC-10-8200002	CLAMP PLANE	1
5	TC-10-8200003	PIN	1
6	TC-10-8200004	SPRING	1
7	GB894. 1-10	SHAFT ELATIC BIG RETAINING RING A-TYPE	1
8	GB879. 1-5×26	ELASTIC CYLINDRICAL PIN, HEAVY	3
9	GB95-4	FLAT WASHER	1
10	GB818-M4×16-H	CROSS PANHEAD SCREW	1

designed by:

checked by:

approved by:

TC-10-8400000 TIRE PRESSER ASSEMBLY

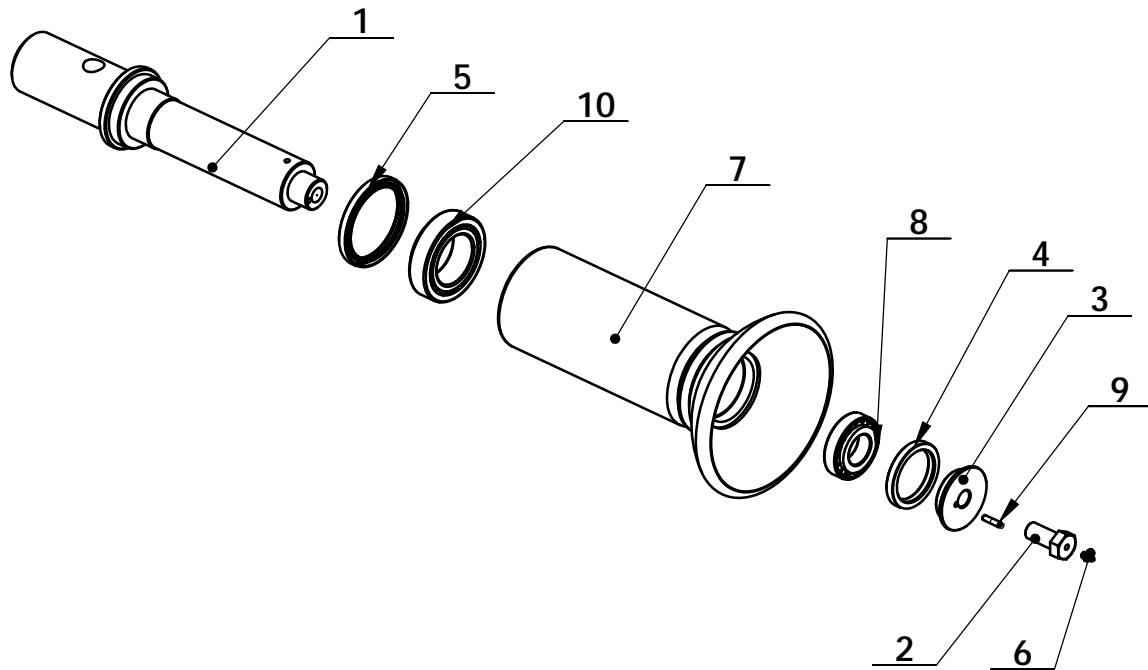

ITEM	PART. No	DESCRIPTION.	QTY
1	TC-10-8400001	PRESS ROLLER SHAFT	1
2	TC-10-8400002	BOLT	1
3	TC-10-8400003	SHAFT RETAINING RING	1
4	TC-10-8400004	SEALING 50*65*8	1
5	TC-10-8400005	SEALING 70*88*8	1
6	TC-10-8400006	OIL CUP M6	1
7	TC-10-8410000	PRESS ROLLER HOUSING	1
8	GB297-30206	CONIC CYLINDER BEARING 30206	1
9	GB119.1-5×20	CYLINDRICAL PIN	1
10	GB297 -33110	CONIC CYLINDER BEARING 33110	1

designed by:

checked by:

approved by:

TC-10-1A00000 ELECTRICAL CONTROL CABINET 380V 50Hz

REVISION A-01

TC-10-1000000

ITEM	PART.No	DESCRIPTION.	QTY
1	TC-40-1910000	ELECTRICAL CONTROL CABINET	1
2	TC-40-1920000	ELECTRICAL CABINET WELDING	1
3	TC-10-1A10000	ELECTRICAL CONTROL CABINET	1
4	TC-40-1900010	INDICATING LIGHT	1
5	TC-40-1900017	CABLE LOCK M27X1.5 PG21	1
6	TC-40-1900018	SEAL RUBBER BAR	1
7	TC-40-1900019	DOOR LOCK	1
8	TC-40-1900020	CABLE LOCK HEAD M20X1.5	3
9	GB95-4	FLAT WASHER	2
10	GB882-4×30	PIN SHAFT	2
11	GB91-1.2×12	SLOTTED PIN	2
12	TC-20-1750000	CABLE LOCK m25*1.5	1
13	GB818-M4×10-H	CROSS PANHEAD SCREW	2

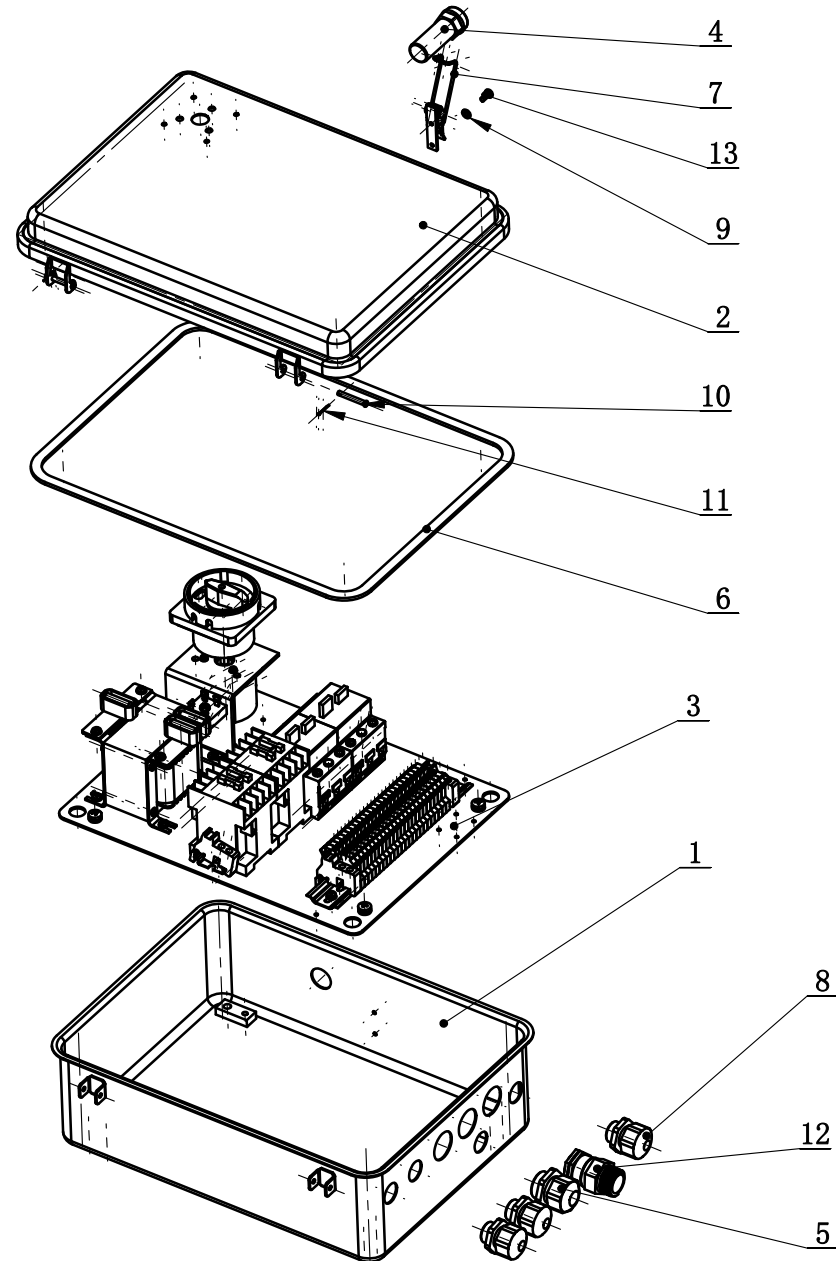

designed by: checked by: approved by:

TC-10-1000000

ITEM	PART. No	DESCRIPTION.	QTY
1	TC-40-1900001	SWITCH HOLDER	1
2	TC-40-1900002	ELECTRICAL BLOCK BOARD	1
3	TC-40-1900004	LONG FIXED PLATE 35mm	1
4	TC-40-1900005	TRANSFORMER ASSEMBLY JBK-100	1
5	TC-40-1900006	DISJUNCTOR	1
6	TC-40-1900007	DISJUNCTOR	1
7	TC-40-1900008	AC CONTACTOR S-P12	2
8	TC-40-1900009	RECTIFIER BRIDGE BLOCK KBPC-2510	1
9	TC-40-1900011	COMBINED SWITCH ASSEMBLY	1
10	TC-40-1900012	POWER-LINE TERMINAL	22
11	TC-40-1900013	POWER-LINE TERMINAL	3
12	TC-40-1900014	FIXTURE CLAMP	4
13	TC-40-1900015	FUSE-6A	1
14	TC-40-1900016	FUSE-6A	2
15	GB95-6	FLAT WASHER	4
16	GB95-4	FLAT WASHER	11
17	GB95-3	FLAT WASHER	3
18	GB93-3	STANDARD SPRING WASHER	3
19	GB93-4	STANDARD SPRING WASHER	4
20	GB93-6	STANDARD SPRING WASHER	4
21	GB818-M4×14-H	CROSS PANHEAD SCREW	1
22	GB818-M4×10-H	CROSS PANHEAD SCREW	10
23	GB818-M6×10-H	CROSS PANHEAD SCREW	4
24	GB818-M3×20-H	CROSS PANHEAD SCREW	3
25	TC-40-1900003	GUIDERAIL 35MM/220MM	1

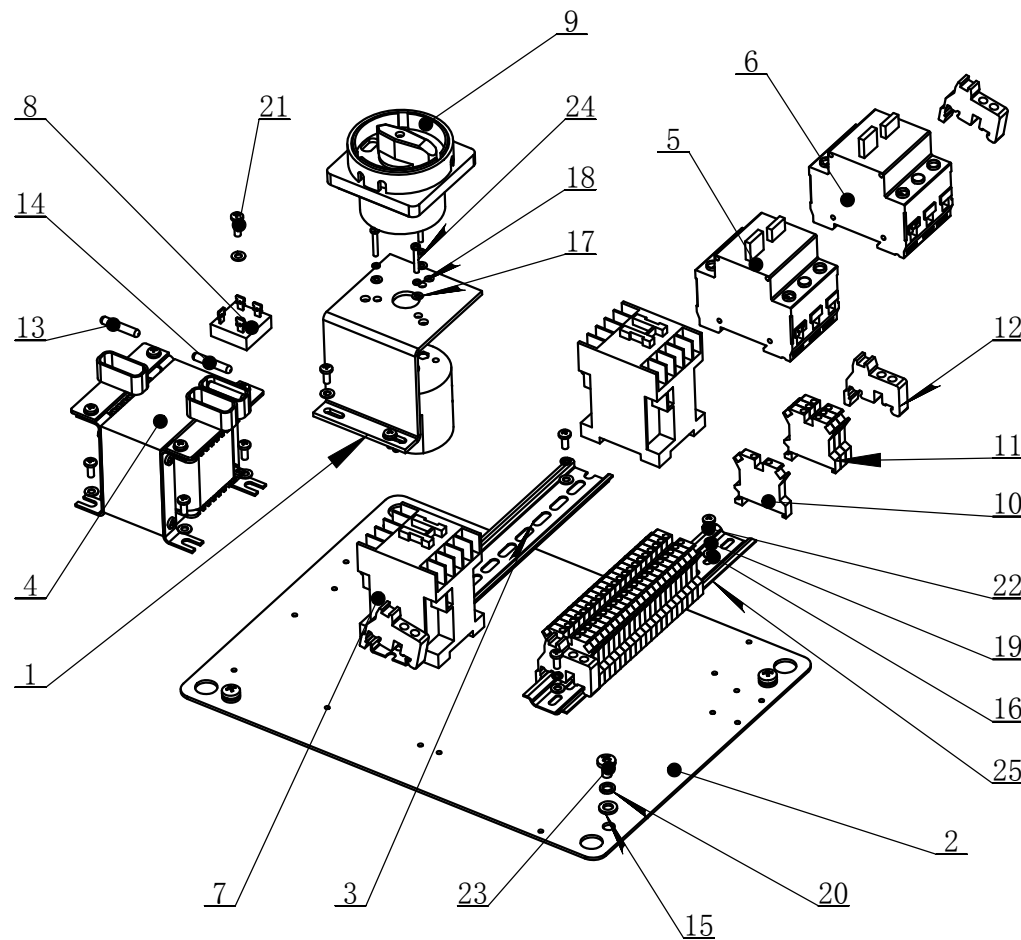

designed by: checked by: approved by:

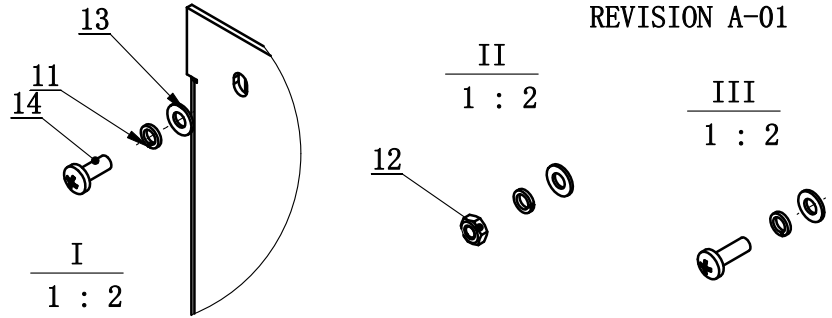
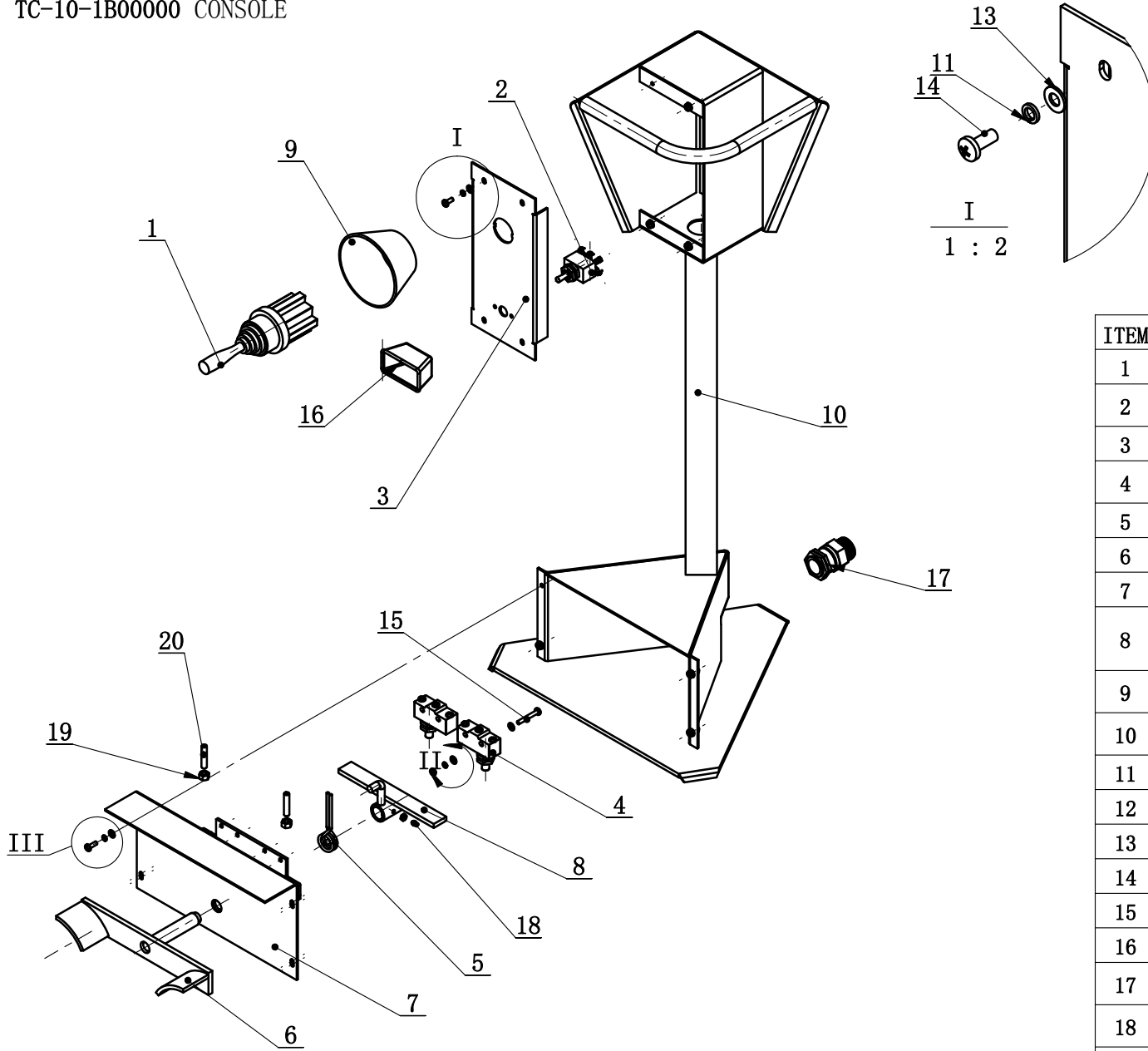

ITEM	PART. No	DESCRIPTION.	QTY
1	TC-20-1700006	CROSS SWITCH TMRN-30	1
2	TC-20-1700003	TOGGLE SWITCH	1
3	TC-20-1700002	COVER	1
4	TC-20-1700005	MICROSWITCHE	2
5	TC-20-1700001	TORSION SPRING	1
6	TC-20-1730000	SHIFT DIRECTION SHAFT	1
7	TC-20-1720000	BRACKET	1
8	TC-20-1740000	SHIFT DIRECTION BUSHING	1
9	TC-10-1B00001	CROSS SWITCH COVER	1
10	TC-10-1B10000	CONSOLE WELDING	1
11	GB93-4	STANDARD SPRING WASHER	12
12	GB6170-M4	HEXANGULAR NUT 1-TYPE	9
13	GB95-4	FLAT WASHER	20
14	GB818-M4×10-H	CROSS PANHEAD SCREW	4
15	GB818-M4×30-H	CROSS PANHEAD SCREW	4
16	TC-20-1700004	PROTECTIVE COVER	1
17	TC-20-1750000	CABLE LOCK m25*1.5	1
18	GB77-M4×8	INNER HEXA FLAT TERMINUS SET SCREW	1
19	GB41-M6	HEXANGULAR NUT	2
20	GB77-M6×30	INNER HEXA FLAT TERMINUS SET SCREW	2
21	GB818-M4×12-H	CROSS PANHEAD SCREW	4

designed by: checked by: approved by:

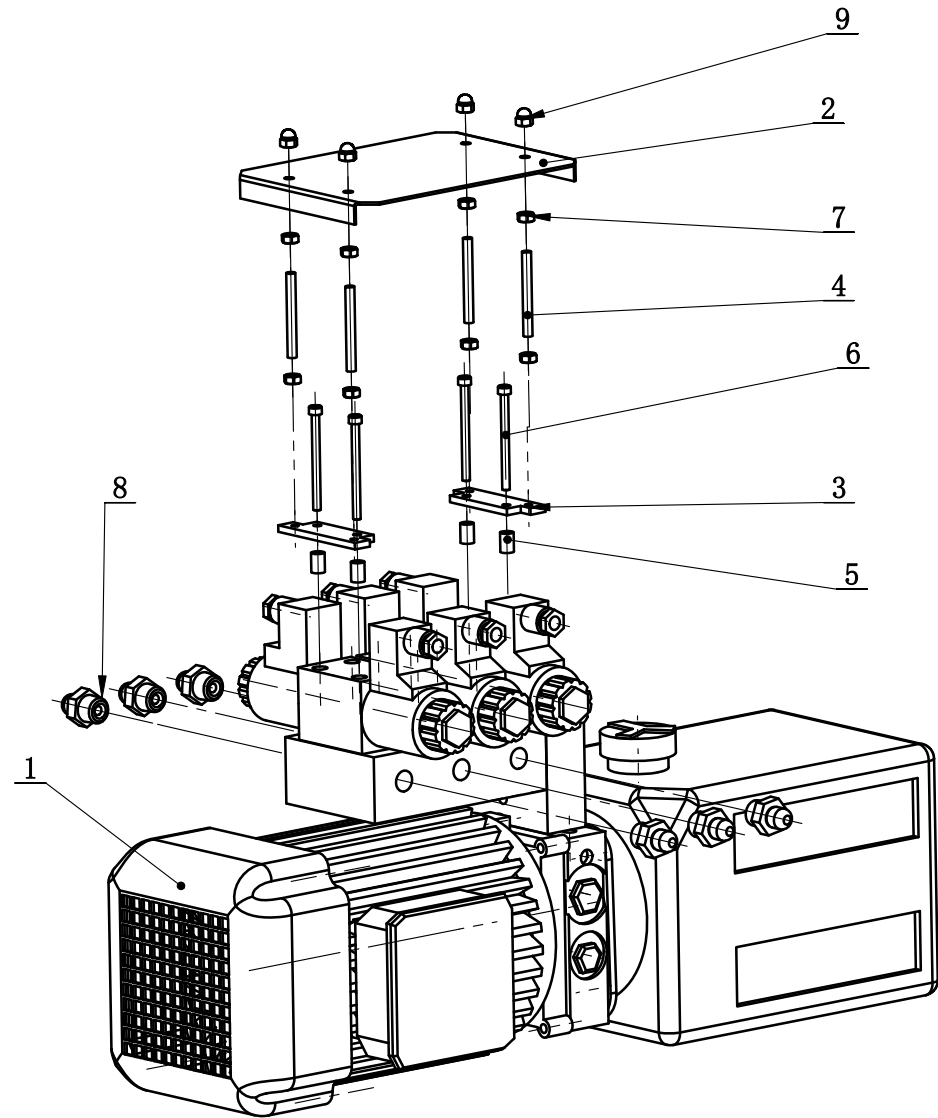

ITEM	PART.No	DESCRIPTION.	QTY
1	TC-10-1031000	pumping station assembly	1
2	TC-10-1030001	electromagnetism valve cover	1
3	TC-10-1030002	electromagnetism valve cover support	2
4	TC-10-1030003	DORBLE ROD SCREW	4
5	TC-10-1030004	washer	4
6	GB70- M5×65	hexagonular bolt	4
7	GB6170-M6	HEXANGULAR NUT 1-TYPE	8
8	TC-20-1000001	DOUBLE SCREW	6
9	GB923-M6	CAP NUT	4

designed by:

checked by:

approved by: